

Instructions: There are 8 short questions and 5 problems. The points allocated to each of the questions are as indicated. The problems are all equally weighted with an assigned weight of 16 points each. All work should be included on the exam itself. Attach additional sheets only if you run out of space on a problem. Students may bring 2 pages of notes to the exam. Calculators are permitted but can not be shared.

Questions:

1. (2pts) What parameter of the op amp characterizes the maximum rate of change in the output voltage?
2. (2pts) If the input terminals of the operational amplifier for the basic inverting amplifier are interchanged, is the resultant circuit an inverting or a noninverting comparator?
3. (2pts) What is a typical value for the dc gain of a 741 operational amplifier?
4. (3pts) If an op amp is modeled by the expression  $A(s) = \frac{GB}{s}$  and if the GB of the op amp is 2MHz, what will be the magnitude of the gain of the op amp at 1KHz?
5. (2pts) If a noninverting voltage amplifier were built and the output due to a sinusoidal oscillation was observed to be clipped at the output on the top and bottom of the waveform at a p-p level that was 50% of the supply voltage (i.e.  $0.5 \cdot (V_{DD} - V_{SS})$ ), what nonideal parameters of the op amp would result in this type of distortion?
6. (2pts) If an inverting voltage amplifier with a large gain were built to amplify a small sinusoidal signal and the output waveform was observed to be sinusoidal but with a much lower amplitude than predicted by a theoretical analysis assuming an ideal operational amplifier, what nonideal property of the operational amplifier would be likely contributing to this degradation in performance?

7. (2pts) If a noninverting comparator with hysteresis were built and you measured the input signal to the amplifier and found it to be in the hysteresis loop, (i.e.  $V_{HYL} < V_{IN} < V_{HYH}$ ), what can be concluded about the output voltage?
8. (5pts) For the following circuit determine the characteristic equation and the dead network.

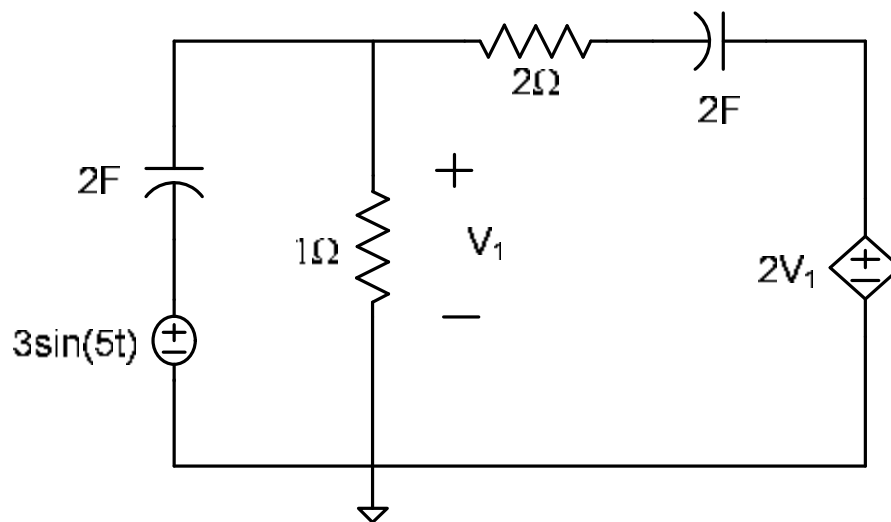

Problem 1 Determine the 3dB bandwidth of the following four systems. Unless stated to the contrary, assume that the GB of the op amps is 1.5MHz.

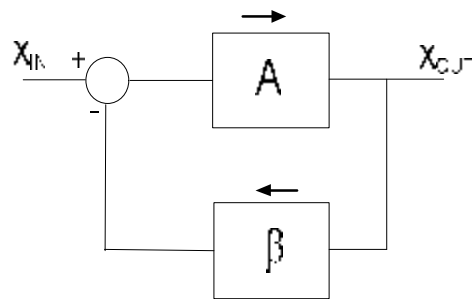
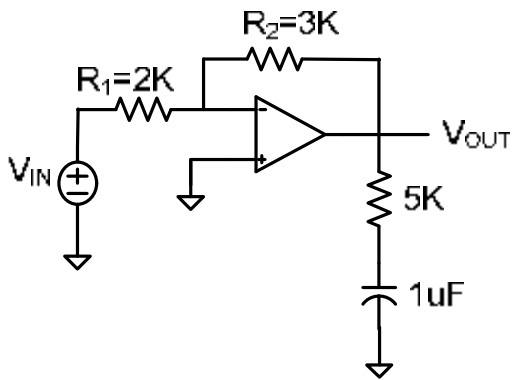
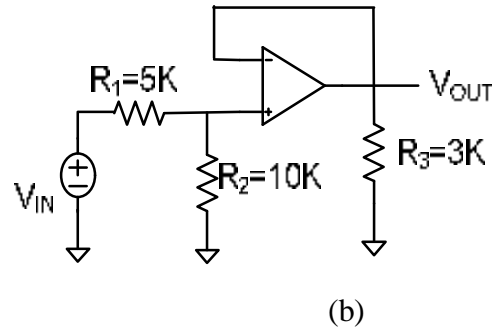
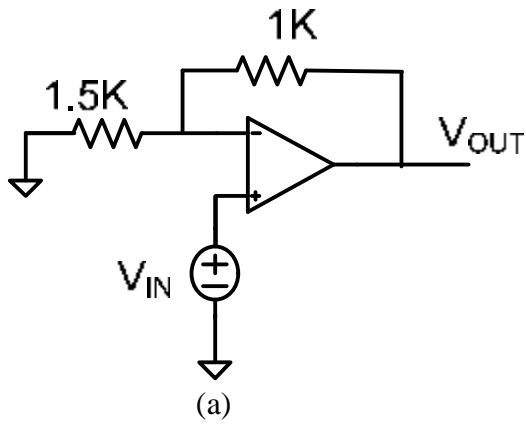

$$A(s) = \frac{15}{(s+4)} \quad b = 0.5$$

(c)

(d)

Problem 2 Assume  $V_{IN}$  is a sinusoidal signal and that the capacitors are very large in the circuits shown. Determine the desired voltage gain and the worst-case output offset voltage for the two circuits shown. Assume the op amps are ideal except for an offset voltage specification of 5mV.

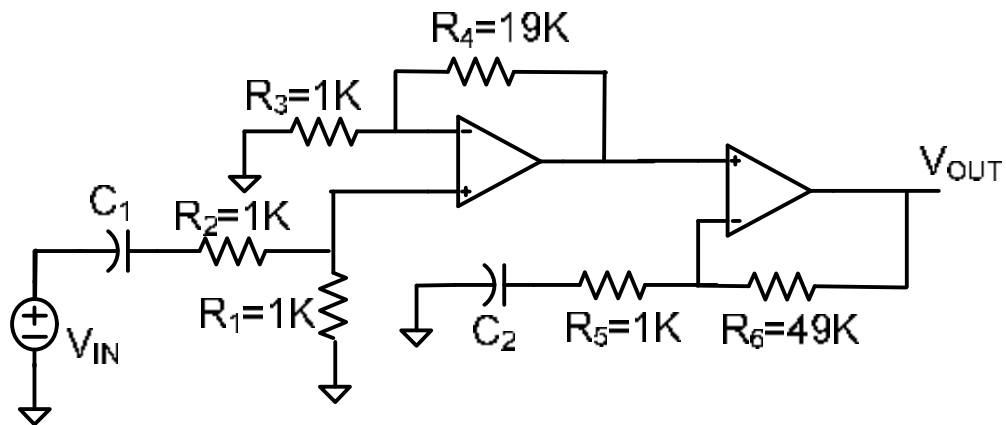
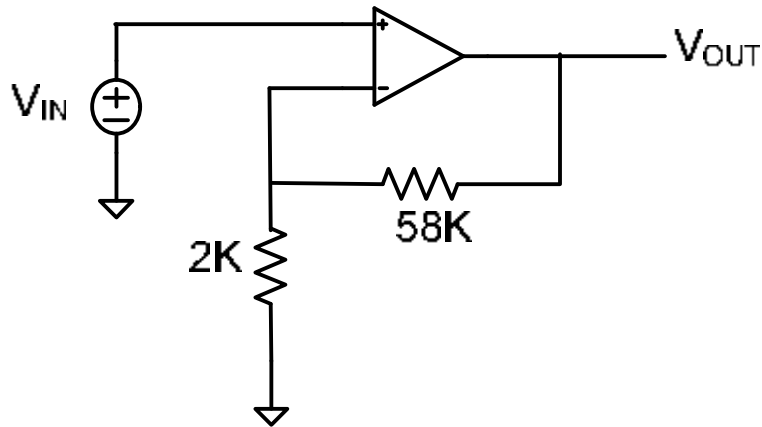

Problem 3 Assume the op amp is ideal except for a frequency-dependent voltage gain that can be modeled by the gain expression  $A(s) = \frac{GB}{s}$ .

- Determine the ideal dc voltage gain  $A_{FB} = V_{OUT}/V_{IN}$
- Determine the characteristic equation for this amplifier
- Determine the poles and zeros for this amplifier
- If  $R_1 = 10K$ ,  $R_2 = 90K$ , and  $R_3 = 100K$ , determine the minimum value of  $R_4$  that can be used if the amplifier is to be stable

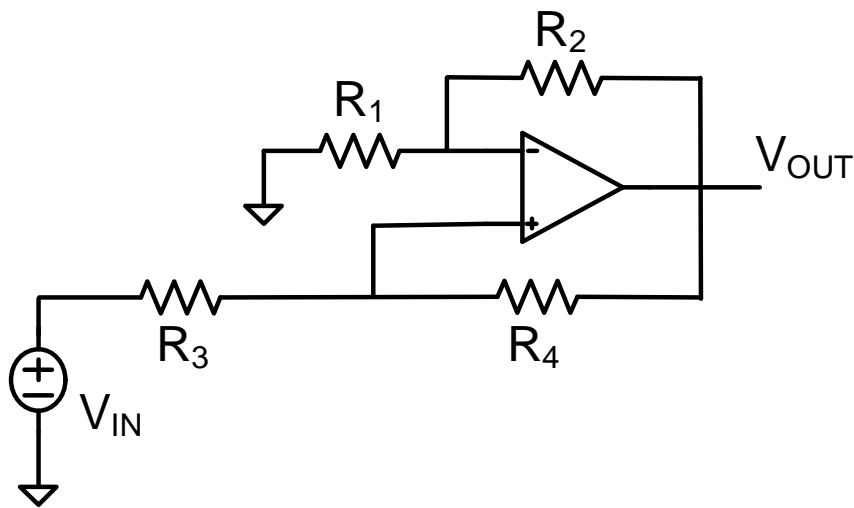

Problem 4 Design a comparator that has the following transfer characteristics. You have available resistors, dc power supplies, and op amps for your design.

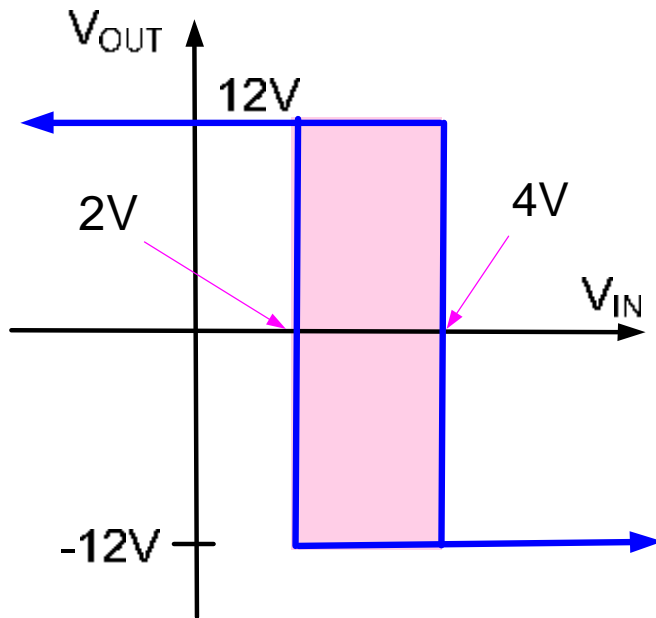

Problem 5

The three-terminal nonlinear device shown is characterized by the equations

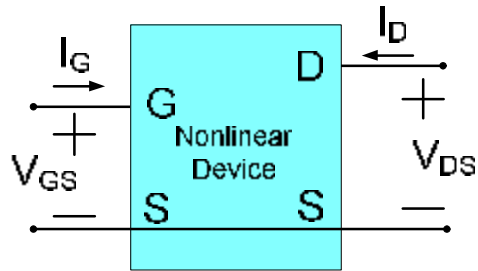

$$I_G = 0$$

$$I_D = \begin{cases} 0 & V_{GS} < 1 \\ 10^{-4} \left( V_{GS} - 1 - \frac{V_{DS}}{2} \right) V_{DS} & V_{GS} > 1, \quad V_{DS} < V_{GS} - 1 \\ \frac{10^{-4}}{2} (V_{GS} - 1)^2 & V_{GS} > 1, \quad V_{DS} > V_{GS} - 1 \end{cases}$$

Determine the output voltage of the following circuit that contains this nonlinear device.

